



# SECURITY TECHNICAL SERVICES(PTY)Ltd

## Full Height Automatically Revolving Deluxe Turnstiles – for Contactless Access Control



### Features

Available in single or double configurations, to control:

- entry only
- exit only
- passage in both directions
- 4-arm (90°) and 3-arm (120°) configurations
- Suitable for both indoor and outdoor applications
- Weatherproof header box protecting electronics
- Compatible with all access control systems
- Limits access to authorised persons only
- Optional electronic random search facility for theft control
- Can be configured to free-wheel or remain locked in event of a power failure
- Hot dip galvanised frame for maximum corrosion protection
- Stainless Steel rotor arms
- Silent trouble free operation
- Passage frequency  $\pm 15$  persons per minute

**AUTO-GATE** has been manufacturing turnstiles in a variety of configurations for over 30 years.

These turnstiles have a wide range of applications for high security and high volume access control.

Available in a range of colours with an option to match corporate colour schemes.

The stainless steel arms do not tarnish or scratch and the high quality finish will withstand continuous and prolonged use even in hostile environments.

The Autogate turnstile mechanism is extremely robust and has been designed and manufactured from the highest quality materials providing many years of trouble free service. Tests have shown the heads are mechanically indestructible.

#### Turnstiles Allow :

- Time and attendance monitoring/staff control
- Unmanned secure entrances
- No intimidation of security personnel
- Random search options
- Counting facility which can be remotely monitored
- Ticket sales verification
- Coupling to metal detector alarm – emergency lock up
- Positive locking



FULL HEIGHT TURNSTILES | WAIST HEIGHT TURNSTILES | HALF HEIGHT TURNSTILES | GLASS TURNSTILES | VEHICLE BARRIERS | SPECIAL NEEDS GATES | BOOTHS | INDUSTRIAL GATES | ROTADOORS | AUTOMATION | PEDESTRIAN BARRIERS

© COPYRIGHT 2010 AUTOGATE

For further information : Tel: +27 31 701 0113 Fax: +27 31 702 6280

## Full Height Deluxe Turnstiles

### Ideal for use in:

- Industrial complexes
- Factories
- Mines
- Sports grounds
- Leisure centres
- Public institutions

### Technical Specifications:

- Power Supply : 12V DC
- Pulse time : 0.2 – 0.75 seconds potential free contacts
- Current Draw : 15VA at 12V whilst activated
- Modular electronic control in 11-pin plug-in cartridge
- Auto time-out locking for security
- Point of no return access
- Manual override in power failures or optional power back-up of  $\pm 24$  hours available
- Free-standing unit which bolts down onto floor
- Frame hot dip galvanised (painting optional)
- Rubber block in bush shock absorbing coupling
- Mechanical pawl locking mechanism
- Hardened pins and pawl rollers in double shear coupling
- 100% duty cycle 12V DC solenoids, hard chromed PTFE armatures running in DU bushes
- Spindle locking drum supported at both ends with sealed for life bearings
- WARRANTY : 5 YEARS on mechanical components and 1 YEAR on electronic components

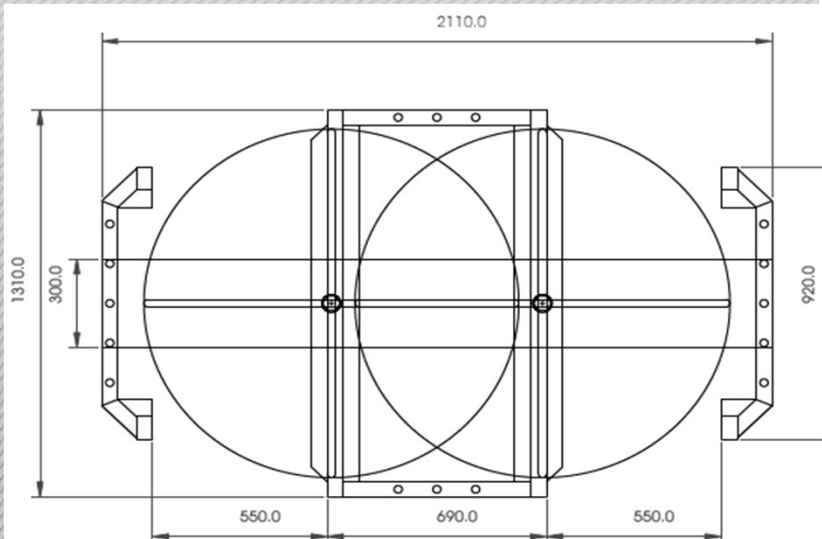
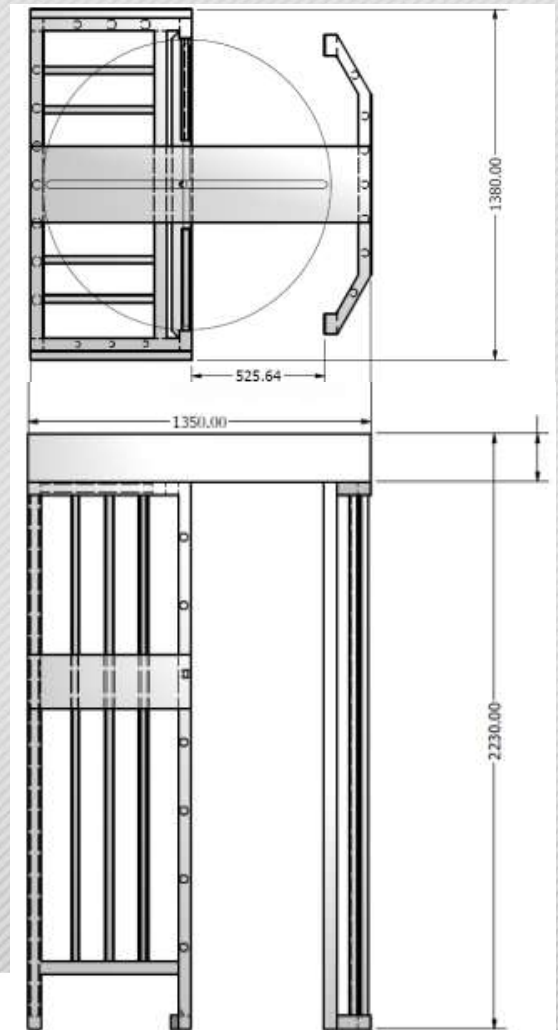

4-ARM DOUBLE TURNSTILE

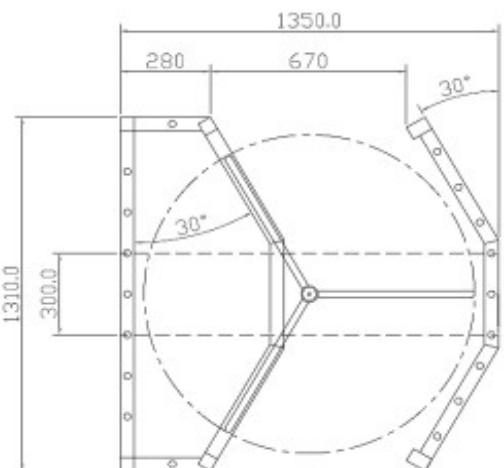

3-ARM SINGLE TURNSTILE